

# YTRON<sup>®</sup>

## PROCESS TECHNOLOGY



**YTRON-ZC**  
**Powder Dispersing**



**YTRON-Z**  
**Inline Homogenizing**

DISSOLVING

MIXING

EMULSIFYING

HOMOGENIZING

SUSPENDING

DISPERSING

GASSING

**YTRON® PROCESS TECHNOLOGY** is a medium size manufacturing company specialising in rotor/stator-systems. The fields of application for this technology include the homogenous mixing of liquids, suspending and dissolving of powders of all kinds, as well as a multitude of different dispersing applications.

With over 50 years of experience, the name of **YTRON®** is known throughout process industries as a leader in new developments, and a quality way above the average with total reliability. In the **YTRON®** premises, built in 2009 in Bad Endorf/Bavaria, innovative technologies are developed for a variety of applications throughout industry. These developments are always under the central guideline of the increasingly important aspects of time and energy saving.

**YTRON®** rotor/stator components are produced using the most up to date machining centres and supplementary components. The Headquarters of **YTRON®**, based in Bad Endorf, include a pilot plant, construction facilities, assembly and quality management.



A continuous and competent development program in our range of products has resulted in **YTRON®** equipment being used in key production applications. These include the leading international companies in food, cosmetic, pharmaceutical and chemical industries.

**YTRON®** is represented in over 50 countries. Competent advice and local after-sales service for the customers are our first priority.

**YTRON-ZC**



## The YTRON-ZC Principle

The powder is sucked in by the strong negative pressure created by the ZC reactor head. Immediately after contacting the liquid phase, the powders are instantly wetted and thoroughly dispersed. This process is actually completed before the powder is fully hydrated. Due to the extremely short time shear forces are applied, the process is a very gentle one. In most cases a single pass operation ensures that even when processing extremely shear sensitive thickeners and gelling agents, the highest viscosity is achieved.

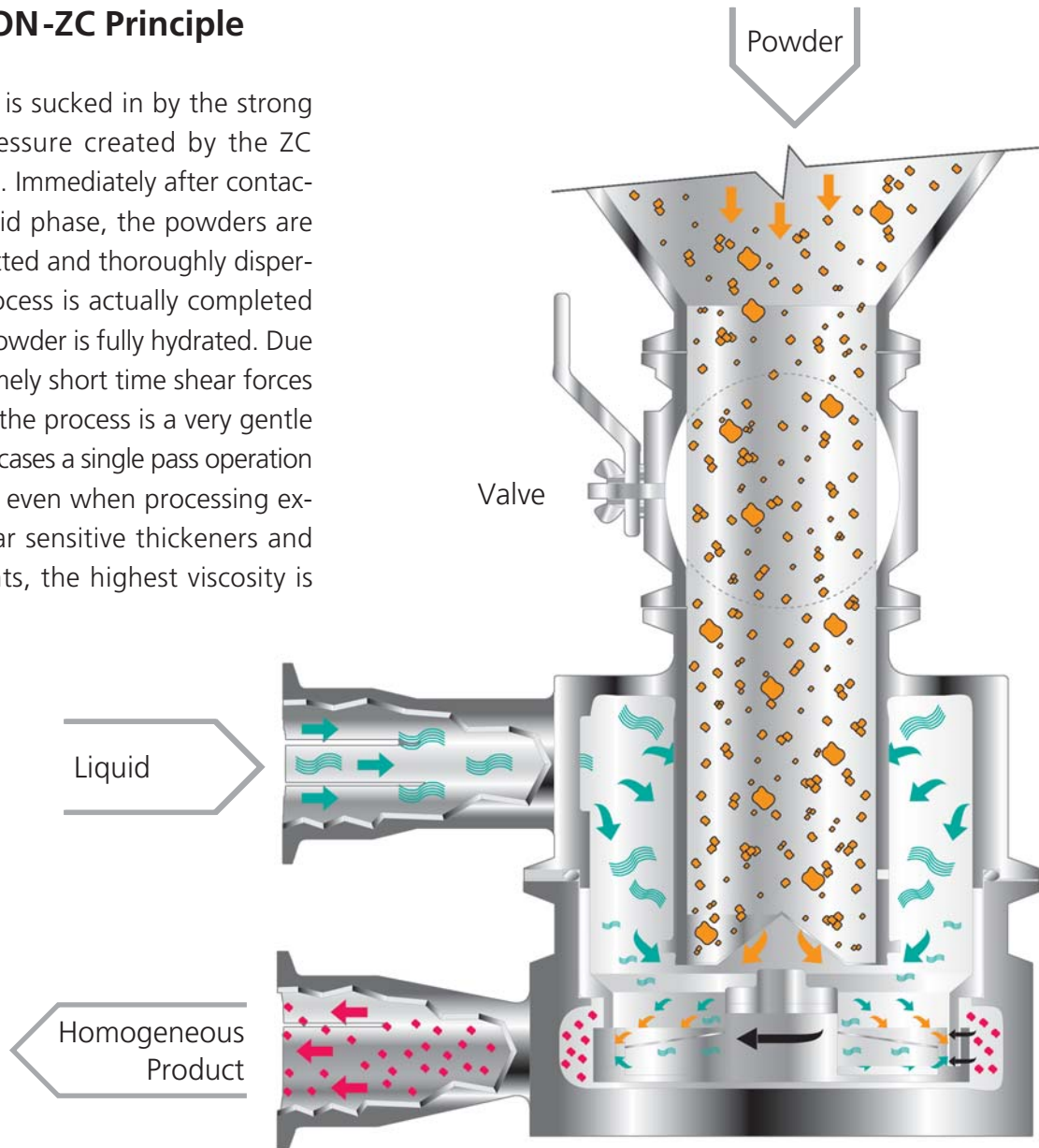

## Important Advantages of YTRON-ZC

- Extremely difficult to wet out powders are processed in a single pass
- The defined application of shear forces results in a STRETCHING® effect of the molecular chain which therefore leads to an increase in viscosity
- Selection of rotor/stator slot width according to the application
- No air entrainment other than the occluded air in the powder phase
- Batch time reduced to the minimum
- High dispersion capabilities at low energy consumption
- Significantly higher yield due to an intensive wetting out of the powders
- Feeding from BigBag or silo is also possible
- Perfectly wetted-out products are achieved in the shortest time
- CIP and SIP available



Product example: Carbopol -  
Concentration approx. 12%



YTRON-ZC in the Dairy Industry  
Application: Dispersing of Stabilizer  
for the production of drinking yoghurt



YTRON-ZC ViscoTron for high viscosities  
and/or solids ratio

## Using the YTRON-ZC for the incorporation of Carbopol®

### The challenge

The use of high molecular weight, cross-linked hydrophilic polymers provides many advantages and enhancements such as efficient gel formation or thickening effect and pseudo plastic properties as well as the stabilisation of suspensions and emulsions. The drawback, however, is that the inclusion of these polymers into the formulation causes considerable difficulties during mixing and dispersing.

The difficulty in dispersing such fine and electrostatically charged powders is their tendency to quickly form agglomerates, as their outer skin hydrates instantly. The resulting tough outer skin may prevent completion of the hydration process creating an agglomeration of particles which are wetted on the outside only. These appear, at best, as small transparent 'fish-eyes' but more generally as lumps of varying sizes, even after longer mixing and swelling stages.

Should an attempt be made to achieve a homogeneous dispersion by smoothing out these lumps through high shear methods, the polymer molecular chain may be damaged. This will affect the end result by reducing the desired rheological characteristics of the finished product, at least partially.

Compromise during dispersing may therefore lead to a reduced viscosity of the final product and adversely affect the reproducibility of the entire process.

### The Solution

YTRON-ZC enables quick, reproducible and problem-free dispersion of „difficult to wet“ gels, gums and thickeners, whilst „STRETCHING“® of the molecular chain at the initial wetting stage means highest achievable yields.

### The use of the YTRON-ZC brings significant advantages

In a single pass, the polymer particles are homogeneously dispersed and fully hydrated. Breakdown of the long chain molecules, resulting in low viscosity, does not occur in the YTRON-ZC as it would in a batch processing method. This is due to the fact that the powder is sheared immediately and only for a fraction of a second after coming into contact with the liquid phase.

The special rotor/stator dispersion reactor effects the "STRETCHING"® of the molecular chain, which can result in a considerable increase in viscosity. The negative pressure created in the dispersing head means a consistent powder intake without the introduction of additional air. The end product is consistently reproducible.

Because the powder/liquid ratio is adjustable, concentrations ranging from 0.5% to 10% can be achieved. The production of a concentrate for later dilution may save time and energy in a later step of the process.

Valuable, ingredients such as liposomes and other shear or heat sensitive products, and encapsulated raw materials can be processed efficiently and without degradation.

### How YTRON-ZC works

The powder is sucked into the dispersing section from the feed hopper. The liquid entering tangentially creates a centrifugal field of liquid in the dispersing section. The powder/liquid mix is immediately dispersed by the labyrinth of rotor/stator teeth. Free discharge from the YTRON-ZC housing is ensured without any clogging or sticking.



YTRON -ZC  
in a bag emptying table  
with dust extraction

Example of a process:  
**InLine** without re-circulation  
 Powder addition from the BigBag

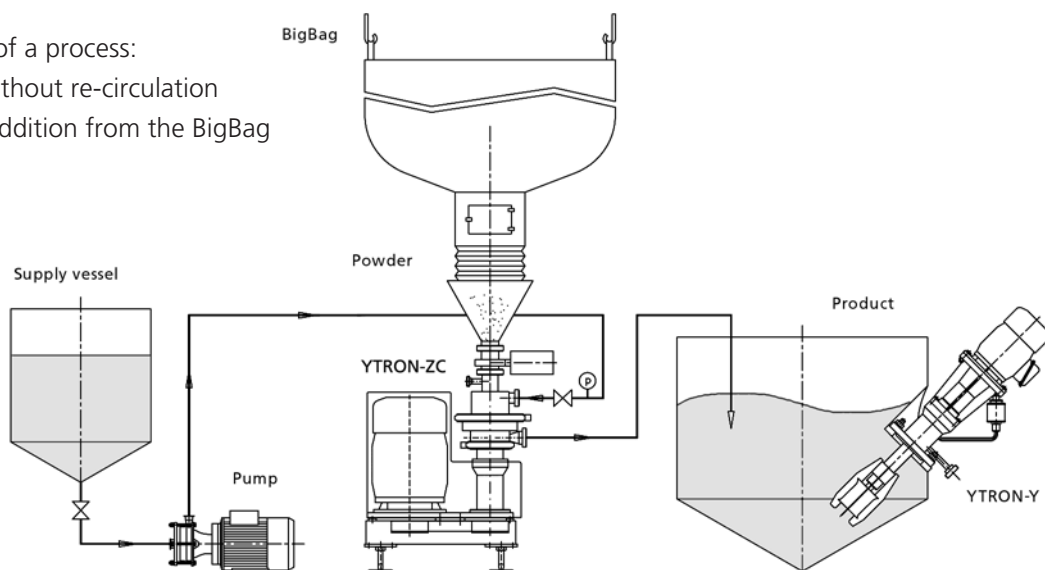

Example of a process:  
**Re-circulation**  
 Powder addition via hopper

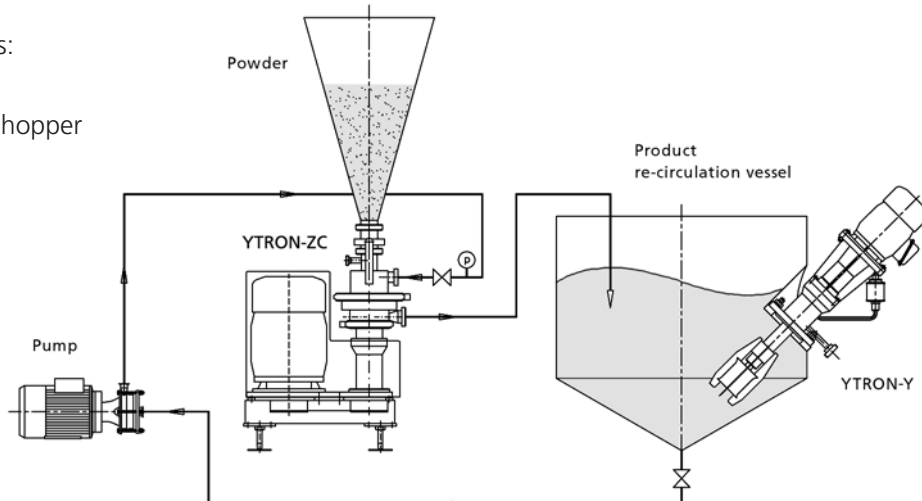

YTRON-ZC with powder addition via silo  
 Application: Suspending of Spices



YTRON-ZC 3 with switchboard and powder hopper for manual powder addition

# YTRON-ZC

Model	ZC-0	ZC 95.6V	ZC-1
Water/liquid flow rate (l/h)	700... 2,400	4,000... 6,000	4,000...10,000
Powder capacity (kg/h) max.	500	1,500	2,000
Rotations (1/min)	6,000	3,000	6,500
Drive power (kW)	2.20	2.20	5.50
Mechanical seal, single acting	Yes	Yes	Yes
Mechanical seal, double acting	Yes (Option)	No	Yes (Option)
Liquid inlet	DN 10	DN 25	DN 25
Liquid outlet	DN 25	DN 40	DN 40
Powder inlet	DN 25	DN 50	DN 50
Standard dimensions approx.*	410x255x470	830x450x870	925x455x660

Model	ZC-3	ZC-5
Water/liquid flow rate (l/h)	9,000...18,000	30,000...90,000
Powder capacity (kg/h) max.	4,500	28,000
Rotations (1/min)	5,000	2,300
Drive power (kW)	15.00	55.00
Mechanical seal, single acting	Yes	No
Mechanical seal, double acting	Yes (Option)	Yes
Liquid inlet	DN 50	DN 80
Liquid outlet	DN 65	DN 100
Powder inlet	DN 65	DN 150
Standard dimensions approx.*	925x455x730	1,120 x 700 x 1,150

According to the application, special construction deviating from standard are available.

\* LxWxH (mm) without pump and powder hopper

## Typical application examples

Difficult to wet out thickeners and gums (binders), stabilizing and gelling agents, e.g. MC, CMC, HPMC, Guar Gum, Locust Bean Gum, Pectin, Agar-Agar, Alginate, Starches, Carrageenan, Xanthan Gum, Milk and Whey based Proteins as well as Polymers with a tendency to stick and form lumps (Poly-acrylic Acids, Carbopol etc.).

In a special configuration, YTRON-ZC is also suitable for very high solids contents in a single pass. Example: Silicates and binders in high viscosity liquids such as sugar syrup and chocolate mass. Please note: In a single pass, the application is particularly gentle for shear sensitive products. Even on multiple passes, the shear rate is reproducible.



**YTRON-Z**



## The YTRON-Z Principle

The reactor head of YTRON-Z houses up to three rotor/stator sets with extremely fine radial tolerances. One or more liquid phases, as well as particles suspended therein, are passed by a forced feed passage through the rotor/stator system. Each set normally consists of three rows of teeth. The inLine-principle effects a defined and reproducible application of shear forces in a single pass.

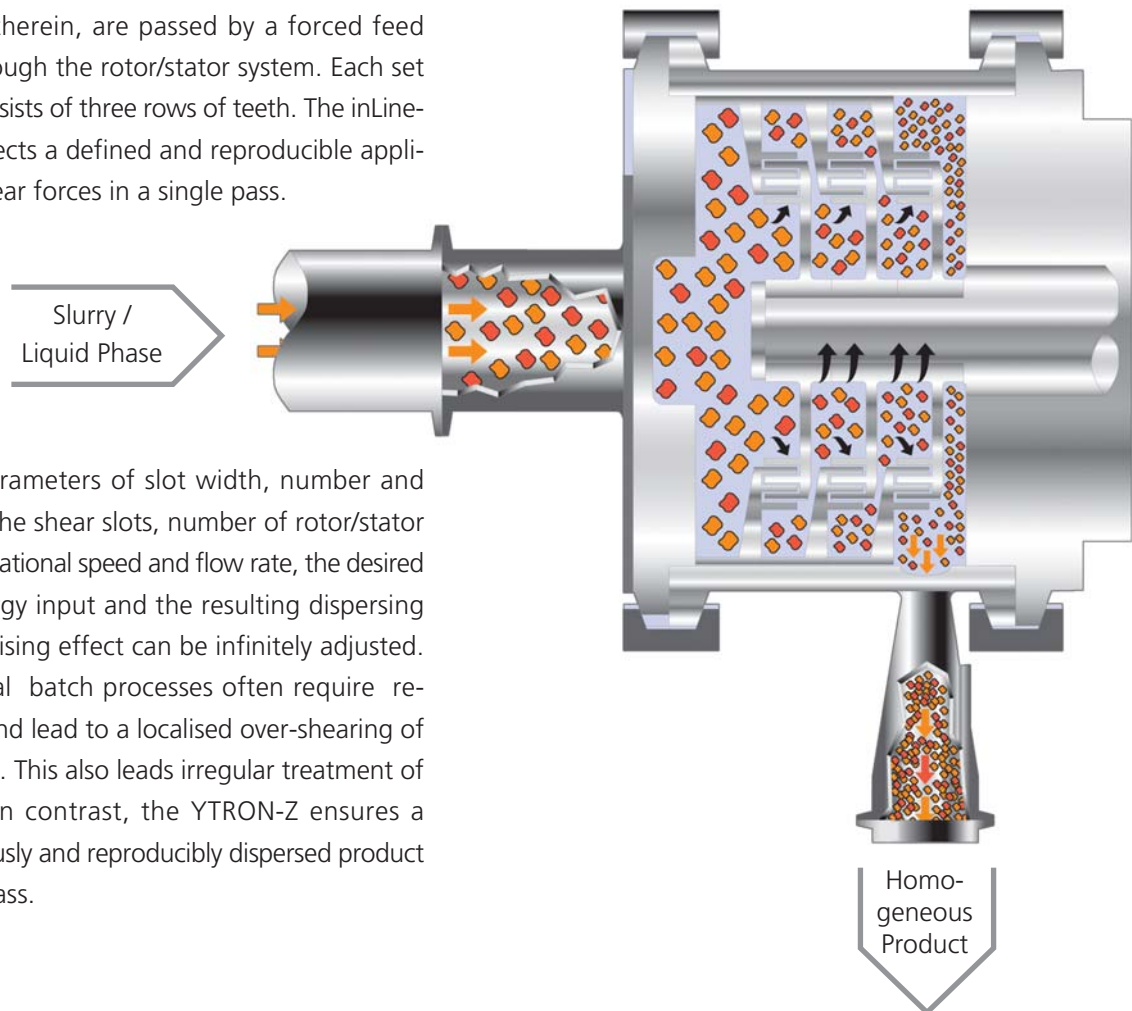

With the parameters of slot width, number and distance of the shear slots, number of rotor/stator sets used, rotational speed and flow rate, the desired specific energy input and the resulting dispersing or homogenising effect can be infinitely adjusted. Conventional batch processes often require recirculation and lead to a localised over-shearing of the products. This also leads irregular treatment of the batch. In contrast, the YTRON-Z ensures a homogeneously and reproducibly dispersed product in a single pass.

## Important Advantages of YTRON-Z:

- Dispersing, de-agglomerating, emulsifying in one pass
- The forced feed passage allows reproducible results
- Gentle treatment of shear sensitive products, e.g. STRECHTING® of yoghurt, direct curd products, fromage frais and cream cheese at low speed
- Homogenising of aromatic oils in liquid systems using medium speeds
- High speed operation to effect a continuous emulsification reaching a droplet size as low as 1µm for various emulsions (o/w and w/o) and dispersions
- Up to three slotted rows of teeth with variable slot widths and finest distance of the slots in each rotor/stator set
- Reactor chamber houses up to three rotor/stator-sets
- Hygienic execution available for use in the food, cosmetic and pharmaceutical industry
- In many applications they are a replacement for a high pressure homogenizer which requires high capital outlay and subsequent maintenance costs



YTRON-Z with flameproof motor  
Application: Variable use in the Laboratory



YTRON-Z with integrated frequency control  
Application: Continuous production of base thickeners in the Textile Printing Industry



YTRON-Z in a mobile construction with frequency converter and YTRON Thermo Unit for seal lubrication

YTRON-Z in hygienic construction and flameproof motor



## Typical Applications:

- Foaming, Aerating
- De-agglomerating
- Emulsifying
- Chemical reaction
- Homogenising
- Wet milling
- STRETCHING®
- Modification of texture and adjustment of viscosity

## Application Examples

- Bitumen
- Tomato Ketchup (cold and hot break)
- Creams and lotions
- Fruit juices
- Soft drinks
- Mayonnaise
- Medical solutions and dispersions
- O/W and W/O emulsions
- Perfume oil and aromatic products
- Pesticides
- S.L.E.S. (continuous dissolving)
- Salad dressing
- Melted cheese and similar products
- Shampoo (continuous production)
- STRETCHING® of yoghurt and fromage frais
- STRETCHING® of thickener slurries
- Soups and sauces

and many more...

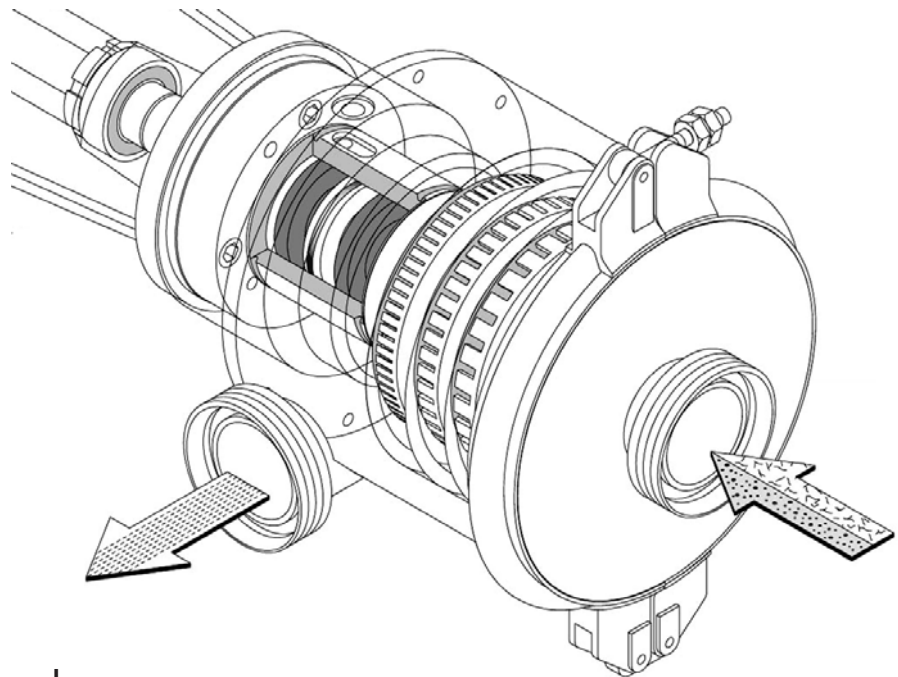

## Some Advantages of YTRON-Z using Examples of Food Applications

- Improved product quality and shelf life stability
- Reduced production times due to a single pass operation
- Reproducibility of results
- Savings of energy, materials and process time when compared to batch procedures and conventional processes
- Flexibility due to interchangeable dispersion tooling
- Improved rheological properties, mouth-feel and texture

YTRON-Z in flameproof execution  
Application: Production of  
Emulsions in the Chemical Industry

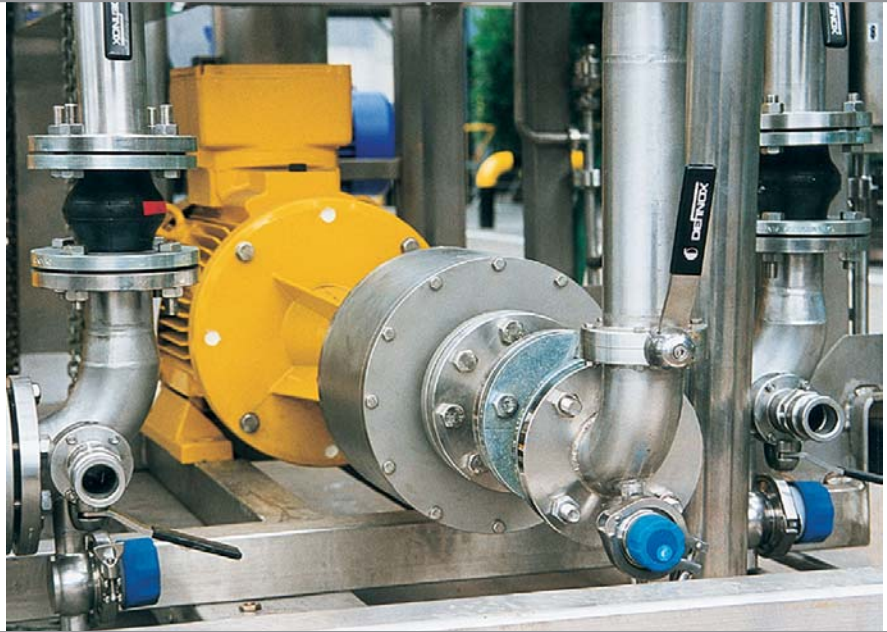

YTRON-Z in the  
Chemical Industry  
Application:  
Homogenising of  
Liquid Detergent  
Emulsions

# YTRON-Z

Model	Z-Lab (Z 0)	Z-60.2V	Z-80 (Z1)
Power (kW)	1.50 ... 2.20	3.00	3.00 ... 7.50
Capacity (l/h)max.	800	2,500	4,000
Hygienic Version	Yes	Yes	Yes
Single acting mechanical seal	Yes	Yes	optional
Double acting mechanical seal	optional	optional	Yes
Pressure (bar)	0 ... 10	0 ... 10	0 ... 10
Fittings (Standard)	DN 25	DN 25	DN 40
Dimensions* LxWxH (mm)	520x200x200	520x200x260	1,060x425x980

Model	Z-130 (Z3)	Z 250 (Z5)	Z-400
Power (kW)	5.50 ... 18.50	7.50 ... 45.00	15.00 ... 75.00
Capacity (l/h)max.	18,000	50,000	90,000
Hygienic Version	Yes	Yes	Yes
Single acting mechanical seal	optional	optional	optional
Double acting mechanical seal	Yes	Yes	Yes
Pressure (bar)	0 ... 10	0 ... 10	0 ... 10
Fittings (Standard)	DN 50	DN 80	DN 125
Dimensions* LxWxH (mm)	1,200x425x980	1,200x450x980	1,900x670x1,070

According to the application, other additional executions, deviating from the standard, are available.

\* In the standard execution

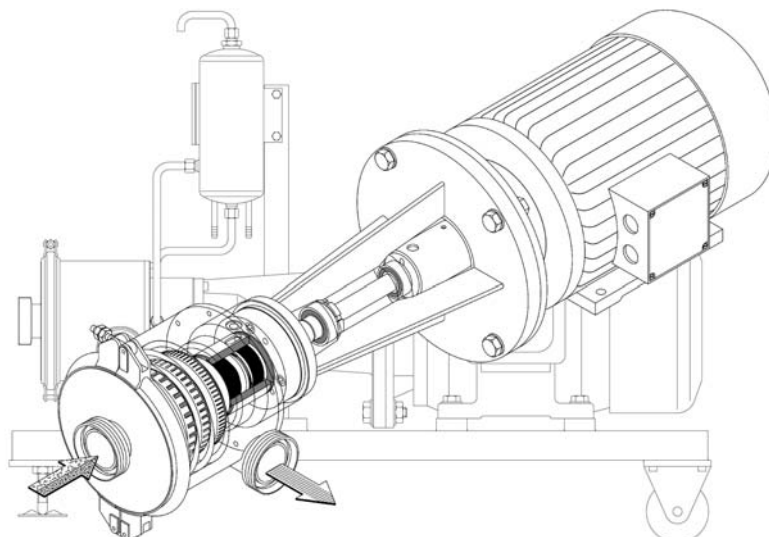



The **YTRON**<sup>®</sup> range is not mass produced

**YTRON**<sup>®</sup> equipment and systems are carefully selected for your individual application. We therefore kindly ask you to provide as detailed as possible a description of your application containing for example:

- Components to be processed
- Viscosity at the beginning and at the end of the process
- The specific gravity (bulk density when adding powders)
- Overall dimensions and shape of the mixing vessel
- Minimum and maximum filling levels of products to be processed
- Working temperature
- Other details that may be relevant

The capacities indicated in this brochure are related to certain applications under standardised conditions. They are not necessarily valid for all products or processes.

The standard materials for the product contact parts are:

- Material 1.4301 / AISI 304
- Material 1.4571 / AISI 316 Ti
- Material 1.4435 und 1.4404 / AISI316 L

Special materials such as 1.4539, Hastelloy etc. are available on request

Fittings can be delivered various types such as  
DIN 11851, DIN 11864, SMS, DS, RJT, Clamp, Flange etc.

We reserve the right to alter the design without previous notice in the interest of development.



**YTRON®**

Process Technology  
GmbH & Co. KG

Handwerkerpark 21  
D-83093 Bad Endorf  
Phone +49 (0) 80 53 /799 10 - 0  
Fax +49 (0) 80 53 /799 10-20  
e-mail: [service@ytron.com](mailto:service@ytron.com)  
Internet: [www.ytron.com](http://www.ytron.com)

*For further informations please contact*